

Synetek DS1-Q

INSTALLATION INSTRUCTIONS

General Description

Model DS1-Q is used to replace and eliminate the factory installed slow responding glow-bar igniter, sensor and associated wiring in commercial laundry tumblers. Model DS1-Q employs instantaneous capacitive discharge for ignition and flame rectification for flame sensing. The control is micro-controller based for high reliability and improved operation, which includes safety pre-purge, multiple ignition trial and LED diagnostics.

SPECIFICATIONS

Input Voltage:	120 VAC (-10% to +15%) 60Hz
Current Draw:	0.50A in Ignition Mode 0.35A in Flame Sense Mode
Pre-purge:	5.0 Seconds Minimum
Ignition Trial:	10.0 Seconds Maximum
Number of Ignition Trials:	3 Maximum
Flame Failure Response:	1.0 Second Maximum
Re-Ignition Trial:	10.0 Seconds Maximum
Number of Re-Ignition Attempts:	20 Maximum
Inter-Purge:	5.0 Seconds Maximum
Lockout:	Reset by interrupting power for 5.0 Seconds
Diagnostic Output:	Steady On: Normal Operation / Call for heat 2 Flashes: Trial Lockout / Burner never lit or Flame never detected 3 Flashes: Re-Ignition Limit Exceeded / Flame signal lost Steady Flash: Flame Detected out of Sequence or Internal Fault
Temperature Range:	+175 to -40 deg.

TOOLS AND MATERIALS REQUIRED

1. Instructions for DS1-Q
2. Wire Cutters
3. Wire Strippers
4. Slot Screw Driver
5. Phillips Screw Driver
6. Pliers
7. #25 Drill & Drill Motor
8. Ruler

INSTALLATION KIT CONTENTS

1. 30" High Voltage Lead
2. Igniter/Sensor
3. Wiring Harness
4. 4 pcs, #8 x 3/4" Hex Head Screws
5. 2 pcs, Crimp Nut
6. 3 pcs, #6 x 1/4" Phillips Head Screws
7. 1 pcs, 120VAC Redundant Coil
(Replaces Boost & Holding Coils)

IMPORTANT

Only persons trained and qualified to service and repair commercial laundry tumblers and ignition controls should attempt installation.

PRE-INSTALLATION INSTRUCTION

1. Read completely through the installation Instruction before attempting installation of DS1-Q
2. Be certain that the dryer is operating correctly. Repair malfunctioning items as required. Installation of Model DS1-Q will not correct any malfunction except for failed glow-bar, sensor or split coils.
3. Locate and mount the DS1-Q control module in the dryer's accumulator compartment if possible. **DO NOT** mount the DS1-Q control module on top of the burner box or on any surface that exceeds 175° F. Excessive heat will damage the control module.
4. Compare the gas valve diagrams in this manual to the gas valve in the dryer and continue the installation procedure according to the instructions for the gas valve in your dryer. If the dryer has a gas valve not identified in this manual **DO NOT ATTEMPT INSTALLATION**. Contact Synetek Controls Inc. at (970) 568-7880 for further instructions.
5. Turn OFF gas and electrical power to the dryer.

INSTALLATION PROCEDURE FOR TYPE 36C REDUNDANT GAS VALVE

1. Be sure **Gas** and **Electrical** power is **off** before continuing.
2. Locate the power leads running to the gas valve from the dryer terminal block. Disconnect the leads at the dryer terminal block and reconnect the **DS1-Q** power leads **#4** (Black Hot) and **#2** (White Return) in the exact same location.
3. Working with the two leads disconnected from the dryer terminal block, follow them to their connection on the gas valve, remove the leads and connect the **DS1-Q** valve leads **#7** (Blue) and **#1** (White) in the exact same location.
4. Connect the gas valve redundant coil leads to the same valve terminals where the **DS1-Q** valve leads are connected.
5. Locate the **Green** "Burner Ground" **#6** Lead. Connect this lead to bare metal on the chassis. The stirrup connector can be pushed under a sheet metal screw. Be certain the metal under the screw is free of paint or rust.
6. Remove the flame sensor and glow-bar assemblies from the dryer. Disconnect their connections at the control relay or ignition relay.
7. Check that each new connection is secure by gently tugging on each wire.
8. If you are satisfied that each of the preceding is correct, go to Igniter/Sensor Probe Installation.

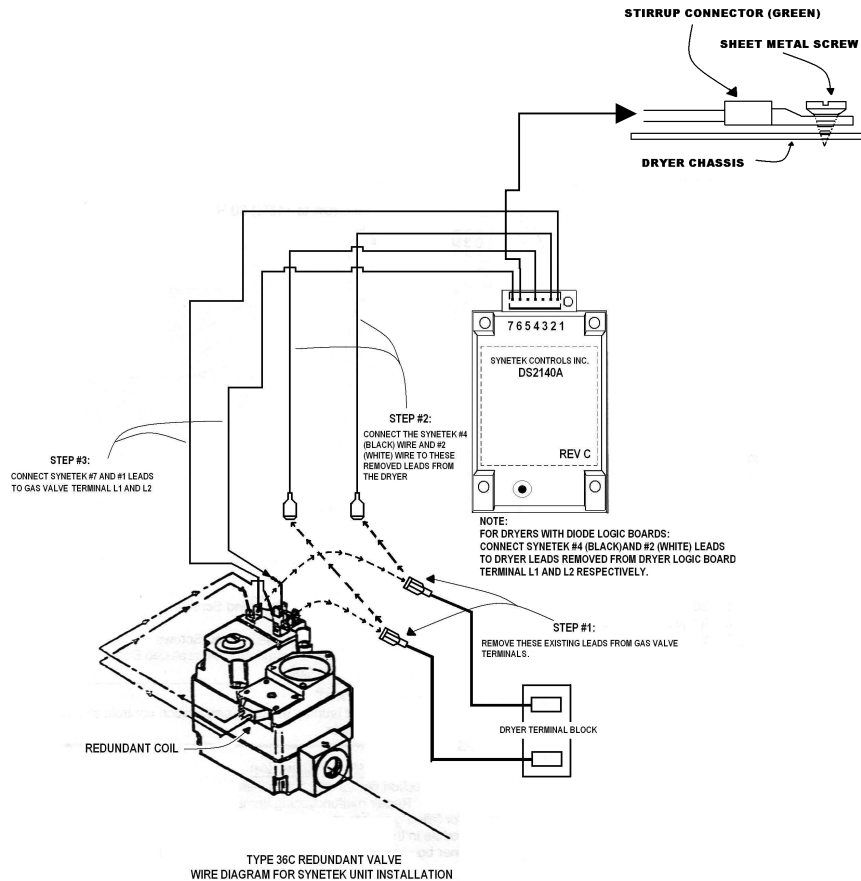

CAUTION!

Property Damage, Injury or Death can result from improper installation!

INSTALLATION PROCEDURE FOR GAS VALVE TYPE 25K

1. Be sure GAS and ELECTRICAL power is OFF before continuing.
2. Remove the plastic cover on top of the gas valve.
3. Locate the coils on the top of the gas valve (three coils located in two brackets). The coil nearest the burner is the existing main coil. The two coils located further from the burner and raised slightly are the boost coil and holding coil.
4. Remove the mounting screws holding the split coil bracket to the gas valve. (Fig A)
5. Remove the bracket over the holding coil, spacer, booster coil, seal plate & o-ring from the gas valve.
6. Install old o-ring, old seal plate, new main valve coil and old coil bracket. Tighten mounting screws.

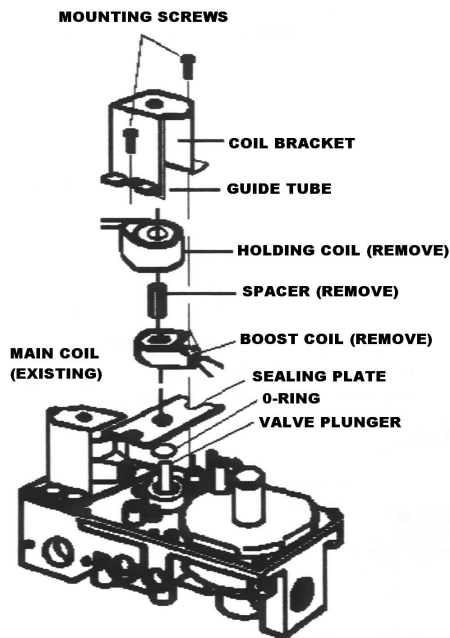

FIG. A. REMOVAL OF BOOST & HOLDING COILS

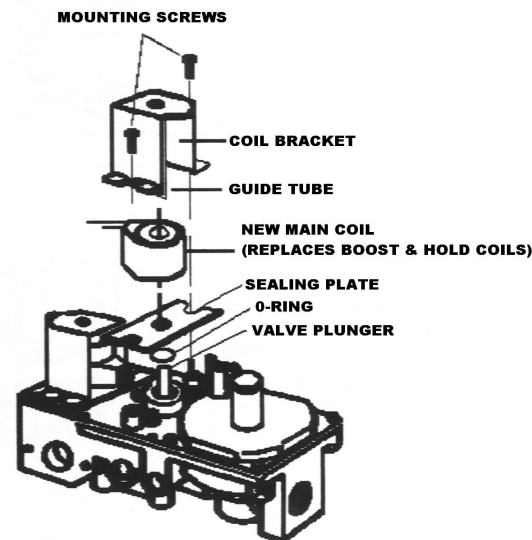

FIG. B. INSTALLING NEW MAIN VALVE COIL

CAUTION!

Property Damage, Injury or Death can result from improper installation!

1. Turn ON gas and use a soap or leak solution to check for leaks. Correct any leaks as necessary.
2. Turn OFF gas.
3. Remove booster & holding coil leads, glow-bar & sensor leads from the dryer. Four (4) leads, two (2) from each coil (existing main coil & new main coil) should remain.
4. Do not remove the leads of the Hi-Lo Coil located on the side of the gas valve, if present.
5. Only two coils should remain on the top of the gas valve. (See Fig TYPE 25K) Using the crimp nut supplied in the installation kit, connect one lead from each main coil to the DS1-Q Blue (#7) lead. Use the other crimp nut to connect the other 2 main coil leads to DS1-Q White lead (#1).
6. Locate the original existing Power Leads that were connected to the gas valve. Connect DS1-Q Black (#4) to one power lead and the White (#2) to the other power lead.
7. Note: Power Leads may connect to the gas valve with a keyed connector or spade terminals. Use wire nut or connect the DS1-Q leads to the power leads.
8. Connect DS1-Q's Green Lead (#6) to the dryer chassis. Make certain the chassis connection is free of paint, rust and other materials, which will prevent a good ground connection.
9. Replace the plastic cover on top of the gas valve.
10. If you are satisfied that each of the preceding is correct, go to the Igniter/Sensor Probe installation section.

INSTALLATION PROCEDURE FOR GAS VALVE TYPE 25K (continued)

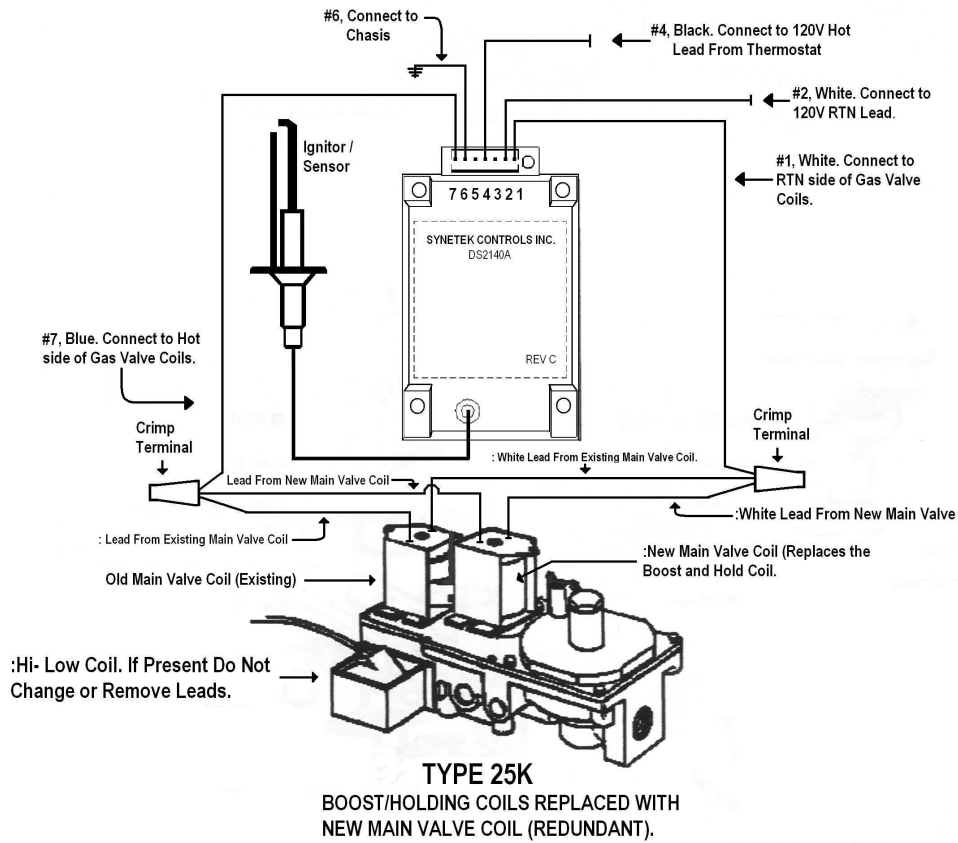

CAUTION!
Property Damage, Injury or Death can result from improper installation!

INSTALLATION PROCEDURE FOR TYPE G96 REDUNDANT GAS VALVE

1. Be sure **GAS** and **ELECTRICAL** power is **OFF** before continuing.
2. Locate the dryer operating thermostat. Remove the dryer lead from the Thermostat and reconnect the **DS1-Q** lead #4 (Black) to the thermostat.
3. Locate the dryer neutral White lead. The neutral lead is the only White lead with a clear plastic double connector. Disconnect the white lead connected to the relay from the plastic double connector. Connect the **DS1-Q** Neutral lead #2 to the plastic double connector.
4. Remove all relay leads, gas valve leads, glow-bar and sensor leads from the dryer.
5. Locate the gas valve operator farthest from the burner, this is the Primary Coil. Connect the **DS1-Q** #7 lead to the right side terminal on the gas valve operator. Connect the **DS1-Q** return #1 (white) lead to the other terminal on the same gas valve operator.
6. Make a blue jumper wire and white jumper wire about 4" long. Install the blue jumper from the #7 (blue) connection on the gas valve operator to the second operator. Repeat this process with the white jumper.
7. Connect the **DS1-Q** Ground #6 (Green) lead to the dryer chassis.
8. Check that each connection is secure by gently tugging on each of the wires.
9. If you satisfied that each of the preceding is correct, go to Igniter/Sensor Probe Installation.

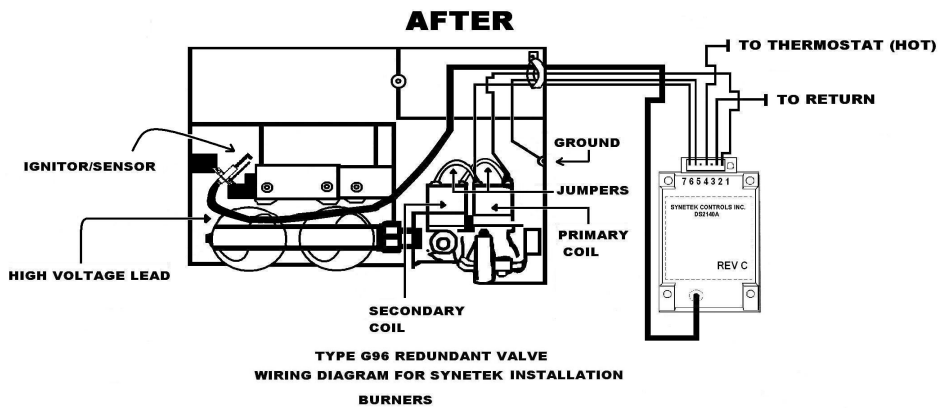
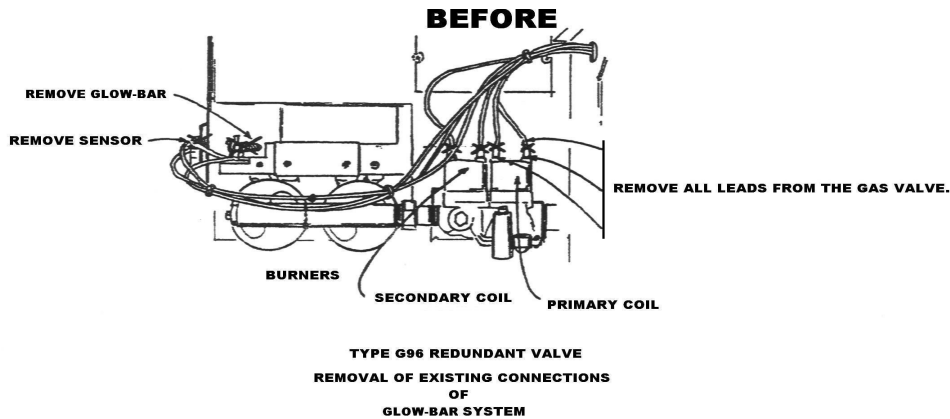

CAUTION!
Property Damage, Injury or Death can result from improper installation!

INSTALLATION PROCEDURE FOR TYPE H91 GAS VALVE (CISSEL DRYERS ONLY)

1. Be sure **GAS** and **ELECTRICAL** power is **OFF** before continuing.
2. Locate the dryer terminal board in the accumulator compartment. Remove the Flame Sensor Leads, Igniter Leads and Operating Gas Valve Leads from the terminal board.
3. Connect the **DS1-Q #7** (Blue) and **#1** (White) leads to the Operating Gas Valve Leads removed from the dryer terminal.
4. Remove the Flame Sensor assembly from the dryer. Disconnect the Glow-Bar leads at the Molex plug and remove the assembly from the dryer.
5. Locate terminal **4** on the dryer terminal board and connect the **DS1-Q #4** (Black) lead to it. Locate terminal **B** on the dryer terminal board and connect the **DS1-Q #2** (White) to it.
6. Connect the **DS1-Q Ground #6** (Green) to the dryer Chassis.
7. Check that each connection is secure by gently tugging on the each of the wires.
8. If you are satisfied that each of the preceding is correct, go to Igniter/Sensor Probe Installation.

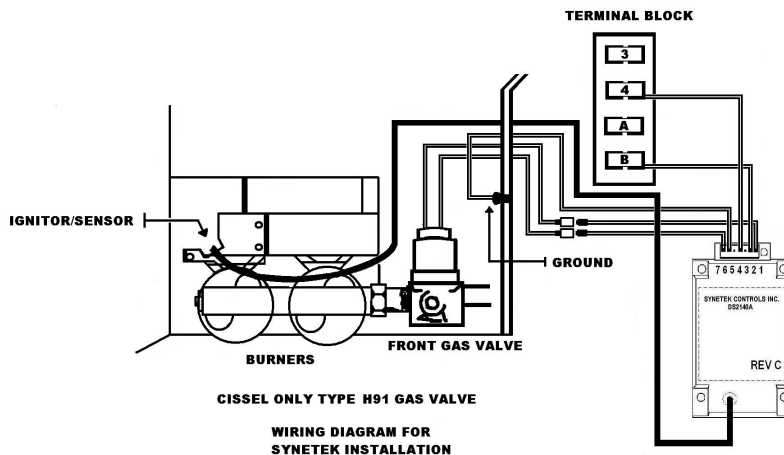
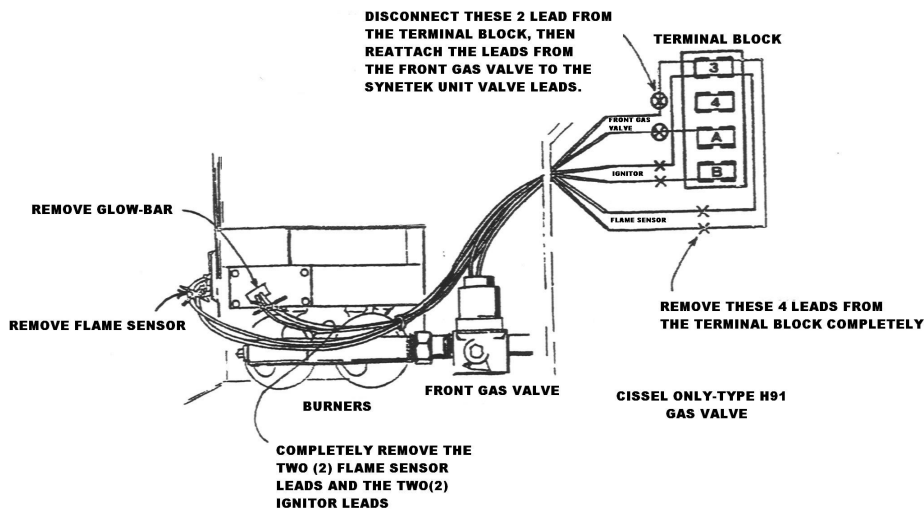

CAUTION!
Property Damage, Injury or Death can result from improper installation!

IGNITER/SENSOR PROBE INSTALLATION

1. Remove the existing glow-bar bracket and flame sensor assemblies.
2. Using a #6 Phillips head screw, locate and mount the Igniter/Sensor Bracket in the same location as the glow-bar bracket. Be certain that the metal Electrode Rod of the Igniter/Sensor is not touching the flame or burner.
3. Check that the distance from the tip of the Igniter/Sensor is no less than $\frac{1}{4}$ " and no more than $\frac{3}{4}$ " over the burner. It may necessary to bend the Igniter/Sensor bracket to achieve the required clearance. Use caution when bending the bracket not to crack the ceramic insulator.

CHECK OUT SEQUENCE

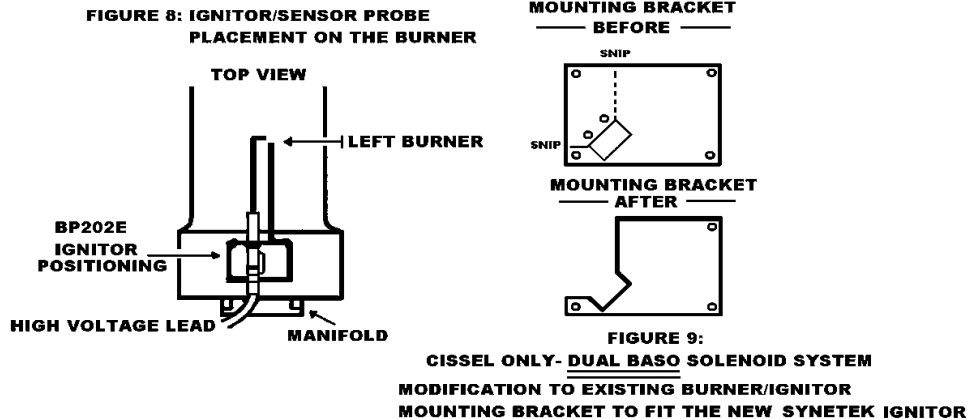

1. Turn ON the power to the dryer (Gas is still OFF) and start the tumbler. Observe the following:
 - A. 5 Seconds after the dryer starts high voltage sparking starts.
 - B. Sparking continues for 10 seconds.
 - C. Sparking stops for 5 seconds.
 - D. Sparking starts for another 10 seconds.
 - E. Sparking stops for 5 seconds.
 - F. Sparking starts for another 10 seconds.
 - G. Sparking stops and the control goes in to safety Lockout. LED flashes 2 times.
2. Reset safety Lockout by opening the dryer door until the tumbler stops and then re-closing the dryer door and restarting the dryer. Observe that the DS1-Q control follows the same sequence as in #1 above.
3. If steps 1 & 2 are satisfactorily completed, turn ON the gas supply to the dryer.

CAUTION!

If you smell gas, immediately turn the gas supply OFF and repair. If you are uncertain or are unqualified to repair the gas leak, contact a qualified repair technician. DO NOT continue the CHECK OUT procedure until the gas leak has been repaired.

4. Start the dryer and observe the following:
 - A. Green LED is ON.
 - B. DS1-Q starts the ignition spark and the flame is established within a few seconds.
 - C. The spark shuts off after the burner is established.
 - D. Burner shuts off after the thermostat is satisfied and re-ignites when the temperature drops.

TROUBLESHOOTING

PROBLEM: No ignition spark, No Gas, **DS1-Q's** LED is OFF.

SOLUTION: No power to the control. 1) Be sure the accumulator has time on it, the door is closed and the thermostat is calling for heat. Check the thermostat, airflow switch and high limit switch. Repair or replace as necessary. Check the wiring harness connector to the **DS1-Q's** and all connections. Repair or replace as necessary. 2) Wiring harness connector revised at **DS1-Q's** connector. Connect as necessary

PROBLEM: No ignition spark, No gas, **DS1-Q's** LED is flashing two times.

SOLUTION: Control is in safety Lockout. Reset by opening the dryer door until the tumbler stops and then restarting the dryer.

PROBLEM: Ignition sparks but main burner will not ignite.

SOLUTION: Check that the spark is arcing across the spark gap. Check the high voltage lead for shorting, replace as necessary. Check the ceramic Igniter/ Sensor for cracks. Replace as necessary.

PROBLEM: HV Lead is burned at the Igniter/Sensor connector.

SOLUTION: Check the lint screen, ducting and fan. Clean, repair or replace as necessary. Check the airflow switch for correct operation. Replace as necessary.

IMPORTANT

DS1-Q is not field repairable. Attempts to repair or tampering with the control could result in property damage, personal injury or death.

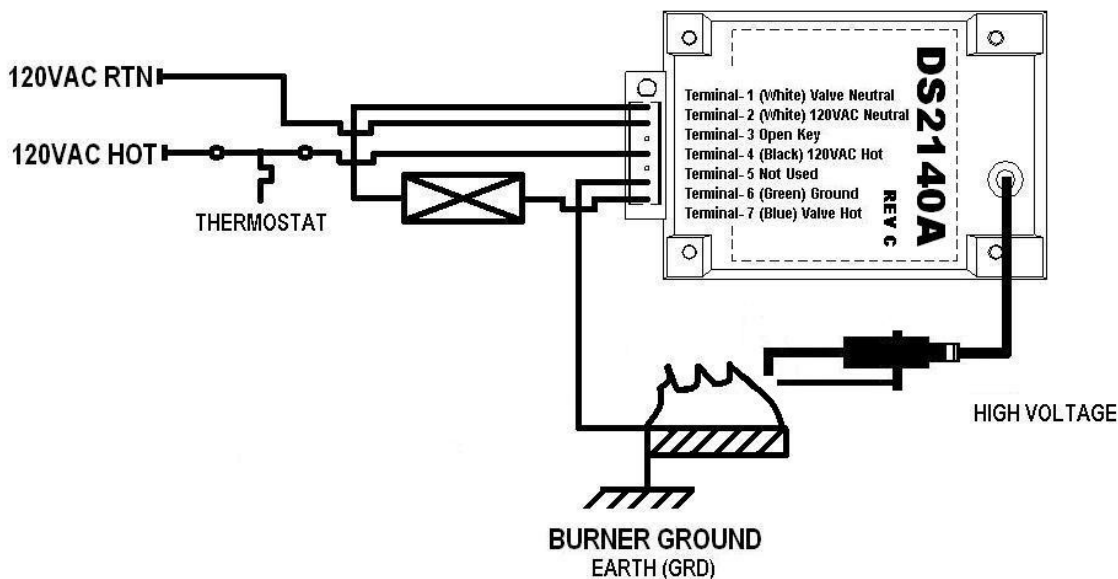

WARRANTY

Synetek Controls, Inc. guarantees to the first retail purchaser that should the control be defective, within the first 24 months of manufacture, and it's our fault, Synetek will repair or replace the control to the first retail purchaser. Synetek is not responsible for equipment down time, labor costs or any other expense associated with the failure or miss application of our control.

Synetek Controls, Inc.

Wellington, CO Phone (970) 568-7880 Fax (970) 568-9460

www.synetek.us